



AGA 7 SERIES INTEGRATED MODULE WITH GAS TOP BURNERS

User Guide & Installation Instructions

CAUTION: THIS UNIT IS HEAVY, PROPER EQUIPMENT AND ADEQUATE MANPOWER MUST BE USED IN MOVING THE RANGE TO AVOID DAMAGE TO THE UNIT OR THE FLOOR.

REMEMBER, when replacing a part on this appliance, use only spare parts that you can be assured conform to the safety and performance specification that we require.

DO NOT use reconditioned or copy parts that have not been clearly authorised by AGA.

WARNING! IF THE INFORMATION IN THIS MANUAL IS NOT FOLLOWED EXACTLY, A FIRE OR EXPLOSION MAY RESULT CAUSING PROPERTY DAMAGE, PERSONAL INJURY OR DEATH

DO NOT STORE OR USE GASOLINE OR OTHER FLAMMABLE VAPORS AND LIQUIDS IN THE VICINITY OF THIS OR ANY OTHER APPLIANCE.

WHAT TO DO IF YOU SMELL GAS:

- **DO NOT TRY TO LIGHT ANY APPLIANCE.**
- **DO NOT TOUCH ANY ELECTRICAL SWITCH;**
- **DO NOT USE ANY PHONE IN YOUR BUILDING.**
- **IMMEDIATELY CALL YOUR GAS SUPPLIER FROM A NEIGHBOR'S PHONE. FOLLOW THE GAS SUPPLIER'S INSTRUCTIONS.**
- **IF YOU CANNOT REACH YOUR GAS SUPPLIER, CALL THE FIRE DEPARTMENT.**

INSTALLATION AND SERVICE MUST BE PERFORMED BY A QUALIFIED INSTALLER, SERVICE AGENCY OR THE GAS SUPPLIER.

**PLEASE READ THESE INSTRUCTIONS BEFORE USING THIS APPLIANCE
AND KEEP IN A SAFE PLACE FOR FUTURE REFERENCE.**

Make a note of your AGA 7 Series Serial Number when it is being installed.

My AGA Details:

Serial No: _____

AGA Service No: _____

Date of Installation: _____

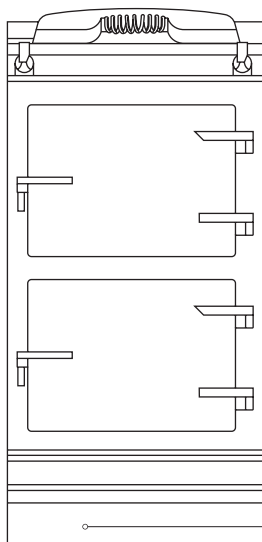







Data badge located
behind cover

Contents

1. Product Safety	1
2. Health & Safety	2
3. Installation Introduction	4
4. Technical Data	8
5. Installation introduction	9
6. Location	10
7. Installation Sequence & Procedure	11
8. Chassis Installation	13
9. Electrical Connections	15
10. Gas Connections	17
11. Final Fitting	18
12. Servicing Notes	19
13. Circuit Diagram	22
14. Servicing and warranty	23

1. Product Safety

Meaning / Description	Symbol	Signification / Description
<p>WARNING / CAUTION</p> <p>An appropriate safety instruction should be followed or caution to a potential hazard exists.</p>		<p>AVERTISSEMENT</p> <p>Une consigne de sécurité appropriée doivent être suivies ou garde d'un danger potentiel exists.</p>
<p>DANGEROUS VOLTAGE</p> <p>To indicate hazards arising from dangerous voltages.</p>		<p>TENSION DANGEREUSE</p> <p>Pour indiquer les dangers résultant des tensions dangereuses.</p>
<p>PROTECTIVE EARTH (GROUND)</p> <p>To identify any terminal which is intended for connection to an external conductor for protection against electric shock in case of a fault, or the terminal of a protective earth (ground) electrode.</p>		<p>TERRE DE PROTECTION</p> <p>Pour marquer bornes destinées à être raccordées à un conducteur de protection extérieur contre les chocs électiques en cas de défaut d'isolement, ou pour marquer la borne de la terre de protection.</p>
<p>HEAVY</p> <p>This product is heavy and reference should be made to the safety instructions for provisions of lifting and moving.</p>		<p>LOURD</p> <p>Ce produit est lourd et doit être fait référence aux consignes de sécurité relatives aux dispositions de soulever et déplacer.</p>
<p>DISCONNECT MAINS SUPPLY</p> <p>Disconnect incoming supply before inspection or maintenance.</p>		<p>APPAREIL À LASER DE CLASSE 2</p> <p>Alimentation d'entrée Débrancher avant inspection ou d'entretien.</p>
<p>REFER TO MANUAL</p> <p>Refer to relevant instructions detailed within the product manual.</p>		<p>ATTENTION, SURFACE TRÈS CHAUDE</p> <p>Reportez-vous aux instructions applicables, indiquées dans le manuel du produit.</p>

IMPORTANT SAFETY INSTRUCTIONS

2. Health & Safety

Consumer Protection

As a responsible manufacturer, we take care to make sure that our products are designed and constructed to meet the required safety standards when properly installed and used.

NOTE: The installation manual and user guide for this appliance are available online on www.agaliving.com.



INCORRECT USE OF THIS RANGE CAN INCREASE THE RISK OF FIRE, ELECTRIC SHOCKS OR INJURY TO PERSONS.

PLEASE READ THE FOLLOWING PRECAUTIONS TO REDUCE THESE RISKS.

- This appliance is not intended for use by persons (including children) with reduced physical, sensory or mental capabilities, or lack of experience and knowledge, unless they have been given supervision or instruction concerning use of the appliance by a person responsible for their safety.
- Children should be supervised to ensure that they do not play with the appliance.
- **PLEASE READ THE ACCOMPANYING WARRANTY.** Any alteration that is not approved by AGA could invalidate the approval of the appliance, operation of the warranty and could also affect your statutory rights.
- **YOUNG CHILDREN SHOULD BE KEPT AWAY FROM THE APPLIANCE AS SURFACES CAN BECOME HOT TO TOUCH.**



ALWAYS

- Always make sure children are never left alone or unsupervised when the range is on.
- Always be aware that range surfaces will be hot during and after use and can cause burns.
- Always teach children that the range and utensils can be hot.
- Always allow heavy and hot utensils to cool in a safe place and out of reach of small children.
- Always be aware hot grease is flammable. Wipe off any grease deposits on the range top and front.
- In the event of a grease fire, do not remove the pan, cover the pan to extinguish the flame.
- Always turn utensil handles inwards but not cover adjacent heated surfaces, to prevent accidental spillage and burns.
- Always when opening an oven door, allow hot air and steam to escape.
- Always use dry pot holders. A moist pot holder will cause steam burns. Do not use towels or other cloths near the heated plates.
- Always clean ventilation hoods frequently. Grease should not be allowed to accumulate in hood and filters.
- Always make sure cabinet and work surface are capable of supporting heavy cooking utensils used on your range.
- Always make sure cooking utensils are suitable for range top service. Only certain types of glass, glass ceramic earthenware/glazed utensils with stand sudden temperature changes without breaking.
- Always make sure your appliance is properly installed and grounded by a qualified technician.
- Always make sure your appliance is serviced by a qualified technician.

IMPORTANT SAFETY INSTRUCTIONS

NEVER

- Never store items of interest to children above the range.
- Never allow children to climb on, sit or stand on any part of the range.
- Never allow children to play with the controls or any part of the range.
- Never wear loose fitting clothing or other flammable materials that could contact hot surfaces on the range.
- Never leave boiling pans unattended, boil over causes smoking and greasy spillovers may ignite.
- Never store gasoline or other volatile liquids in the range or in cabinets above or near the range, which can catch fire or explode.
- Never use water on grease fires. Smother fire or flame or use a dry chemical or foam type extinguisher.
- Never use your appliance for warming or heating the room.
- Never repair or replace any part of the appliance unless recommended in this manual. All other servicing should be carried out by a qualified technician.
- Never cover or restrict the air flow to the controls compartment.
- Never install cabinets (shelves) or similar above the range with a depth greater than 13" (330mm).
- Never heat unopened food containers. Pressure build-up may cause the container to burst and cause injury.
- Never reach directly into a hot oven to add or remove cooking utensils. Instead pull the grid shelf out to its maximum projection.
- Never use a steam cleaner to clean your range.
- Never use a power spray or oven cleaners on the control panel.
- Never use caustic cleaners, abrasive pads or metal scrapers to clean enamel surfaces.
- Never use aluminium foil as a protective liner on the oven base, except as suggested in the manual. Improper use of this type of liner may create a risk of fire.

Deep Fat Frying

- Use a deep pan.
- Never fill the pan more than one-third full of fat or oil
- Never use a lid on the pan.
- **Important:** Oil is a fire risk, do not leave pans containing oil unattended.
- In the event of a fire, cover the pan with a lid and turn OFF the appliance.
- Do not try to fry too much food at a time, especially frozen food. This only lowers the oven temperature of the oil or fat too much, resulting in greasy food.
- Always dry food thoroughly before frying, and lower it slowly into the hot oil or fat. Frozen foods in particular, will cause frothing or spitting, if added too quickly.
- Never heat fat, or fry with a lid on the pan.
- Keep the outside of the pan, clean and free from streaks of oil or fat.

Smother the flames on the hob preferably with a fire blanket, rather than attempting to remove the pan to the outside.

Burns and injuries are caused almost invariably by picking up the burning pan to carry it outside.

When the oven(s) are on **DO NOT** leave any oven door open for long periods, this will effect the temperature of the oven and may allow controls to become hot.

A little smoke and some odor may be emitted when the appliance is first switched on. This is normal and harmless (from oven lagging and starch binder on the element insulation) and will cease after a short period of use.

3. Installation Introduction

Please refer to the eR7 or R7 guide for product dimensions following the Module instructions.

Health and Safety

Consumer Protection

As responsible manufacturers we take care to make sure that our products are designed and constructed to meet the required safety standards when properly installed and used.

⚠ IMPORTANT: Please read the accompanying warranty.

Any alteration that is not approved by AGA could invalidate the approval of the appliance, operation of the warranty and could also affect your statutory rights.

⚠ WARNING: This appliance shall be installed in accordance with the regulations in force and only used in a well ventilated space. Read the instructions before installing or using this appliance.

⚠ CAUTION: This installation must conform with local codes or, in the absence of local codes to the national fuel gas code ANSI.Z223.1 and national electrical code ANSI/NFPA70 (in Canada CAN/CGA-B149) and only used in a well ventilated space, read the instructions before installing or using this appliance.

- Prior to installation, ensure that the local distribution conditions (nature of the gas and gas pressure) and the adjustment of the appliance are compatible.
- The adjustment conditions for this appliance are stated on the data plate.
- The data plate is situated in the centre vent slot near the base of the front plate.
- This appliance is not connected to a combustion products evacuation device. It shall be installed and connected in accordance with current installation regulations. Particular attention shall be given to the relevant requirements regarding ventilation.
- It should be in accordance also with any relevant requirements of the Gas Region and Local Authority.
- The appliance and its individual gas shut off valve must be disconnected from the gas supply piping system during any pressure testing of that system test pressure in excess of ½ psi (3.5 kPa).
- The appliance must be isolated from the gas supply piping system by closing its individual manual shut off valve during any pressure testing of the gas supply system at test pressures equal to or less than ½ psi (3.5 kPa).

- In your own interest, and that of safety to comply with the law, all gas appliances must be installed by an AGA approved installer. Failure to install appliances correctly could lead to prosecution.
- On completion test the gas installation for soundness and purge. Leak testing of the appliance shall be conducted according to the manufacturers instructions.
- **NOTE:** Use soapy water solution on new gas connections to ensure there are no gas leaks.

Delivery Requirements

These installation instructions should be left with the range for the user to retain for future reference.

The AGA 7 Series Module arrives on 1 pallet and attaches to an existing AGA 7 Series range, creating a seamless 5-oven or 7-oven configuration.

See the installation instructions for a detailed description.

If this skate/template can be manipulated through the property grounds and doors into position, then the AGA can be installed as intended with no re-work.

⚠ WARNING: THIS APPLIANCE MUST BE EARTHED.

- The appliance is designed for the voltage stated on the data plate.
- The appliance is supplied with and installed adjacent to the left-hand side of any one of the AGA range.
- Installation of the Module must, therefore, be in conjunction with the build instructions of the 'parent' AGA.
- Reference must be made to the above Installation instructions for the 'parent' AGA especially regarding pre-site inspection, not only for both cookers but to consider any pipework that may pass at the rear of the Module. i.e. boiler piping or flue duct from a Fan Flue AGA.
- The appliance has been designed to accommodate pipework passing at the rear.
- **NOTE! THE MAIN AGA COOKER IS DELIVERED EX-WORKS, UNASSEMBLED.**
- **Assembly is undertaken on site by an authorized AGA distributor.**

Specifications

AGA R7/eR7 with Gas Hob Module

Fig. 3.1

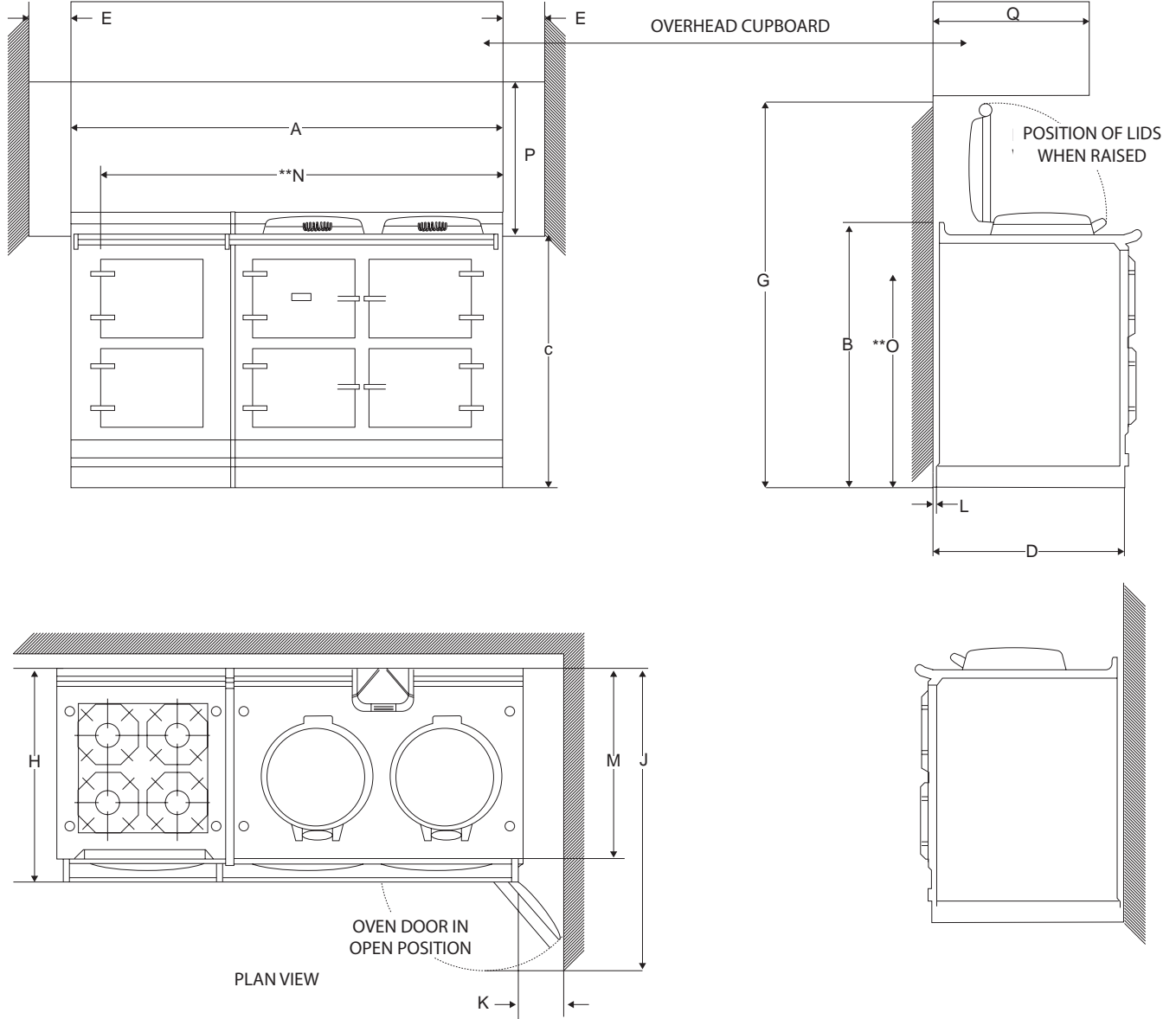

	A	B	C	D	E	G	H	J	K	L	M	N***	O**	P	Q
mm	1598	960	915	680	60	1388	760	1145	125	10	698	1533	800	760	330
ins	62 ⁷ / ₁₆	37 ³ / ₄	36	26 ³ / ₄	2 ⁵ / ₁₆	54 ⁵ / ₈	29 ⁷ / ₈	45	4 ⁷ / ₈	¹ / ₈	27 ¹ / ₂	60 ⁵ / ₈	31 ¹ / ₂	30	13

** POSITION FOR GAS SUPPLY PIPE TO MODULE

DESN 517031

NOTE: When surveying for a cooker installation the actual clearance required for the 'body' of the appliance should be increased overall by ³/₈" (10 mm) beyond the figures quote above. This allows safe margin to take into account the natural dimensional variations found in major castings in particular the width across an appliance recess could be critical.

AGA R7/eR7 with Hotcupboard and Gas Hob Module

Fig. 3.2

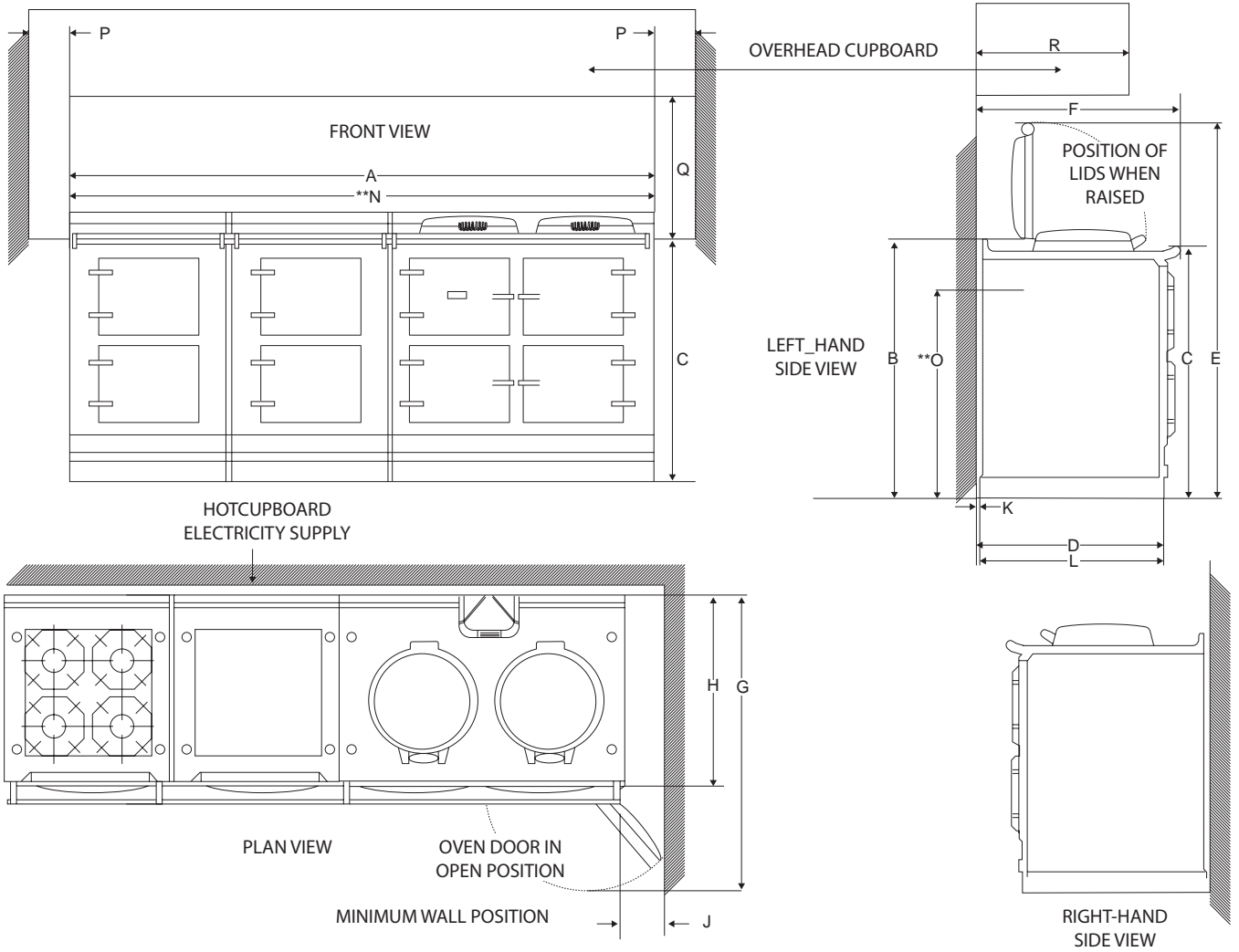

	A	B	C	D	E	F	G	H	J	K	L	**N	**O	P	Q	R
mm	2089	960	915	680	1338	760	1145	698	125	10	634	2033	800	3	760	330
ins	82 1/4	36	36	26 3/4	54 5/8	51 15/16	45	27 1/2	4 7/8	3/8	24 15/16	80 1/16	31 1/2	1/8	30	13

** POSITION FOR GAS SUPPLY PIPE TO MODULE

DESN 517033

NOTE: When surveying for a cooker installation the actual clearance required for the 'body' of the appliance should be increased overall by 3/8" (10 mm) beyond the figures quote above. This allows safe margin to take into account the natural dimensional variations found in major castings in particular the width across an appliance recess could be critical.

Fig. 3.3

Installation Clearance of Combustible Cabinets Adjacent to Range

1/2" clearance to the back of the range may be obtained when installing the appliance against a non-combustible wall or if the wall behind the range is deemed combustible then the minimum spacing from the back of the appliance to the nearest combustible wall is 1 1/2" (38 mm).

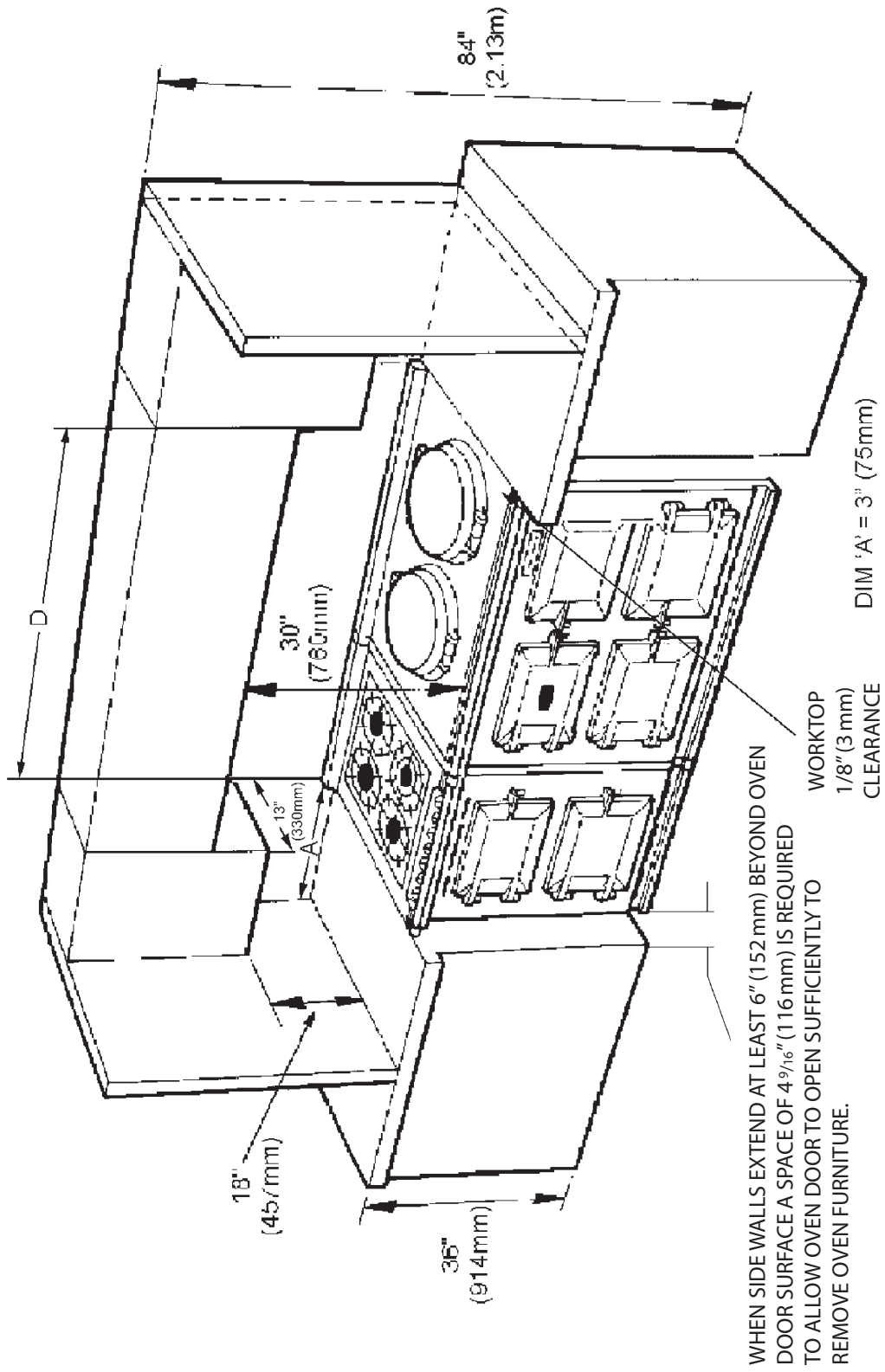

4. Technical Data

HOTPLATE - NATURAL GAS				
	Right-hand Front	Left-hand Rear	Right-hand Rear	Left-hand Front
Burner type	ULTRA - RAPID (WOK)	RAPID	SEMI - RAPID	SEMI - RAPID
Maximum heat input	3.50 kW	3.10 kW	1.80 kW	1.80 kW
Input	12,000 Btu/hr	10,600 Btu/hr	6,150 Btu/hr	6,150 Btu/hr
Injector marking	170	155	118	120

Pressure point position : FRONT LEFT-HAND HOTPLATE INJECTOR

Pressure setting : 4" wg

Burner ignition : H.T. Spark

HOTPLATE - PROPANE				
	Right-hand Front	Left-hand Rear	Right-hand Rear	Left-hand Front
Burner type	ULTRA - RAPID (WOK)	RAPID	SEMI - RAPID	SEMI - RAPID
Maximum heat input	12,000 Btu/hr 3.50 kW (250 g/h) (0.50 l/h)	10,600 Btu/hr 3.00 kW (214 g/h) (0.42 l/h)	6,150 Btu/hr 1.75 kW (125 g/h) (0.25 l/h)	6,150 Btu/hr 1.75 kW (125 g/h) (0.25 l/h)
Injector marking	105	94	72	75

Pressure point position : FRONT LEFT-HAND HOTPLATE INJECTOR

Pressure setting : 10" wg

Burner ignition : H.T. Spark

ELECTRIC GRILL AND OVENS: 230V, 50Hz SINGLE PHASE, 30 AMP	
Grill element power rating	2 x 1.05 kW
Top oven power rating	1.00 kW
Lower oven (fanned)	1.90 kW

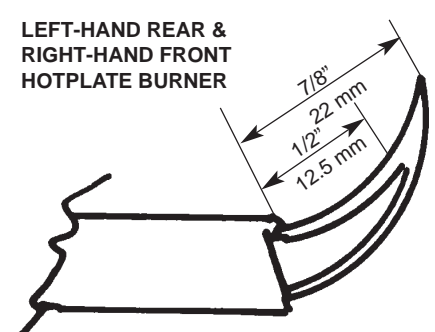
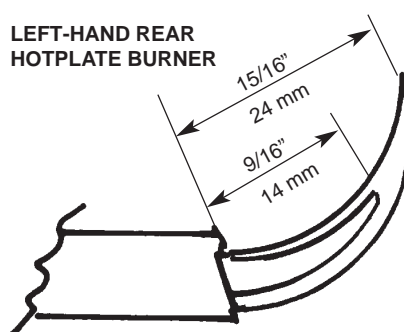
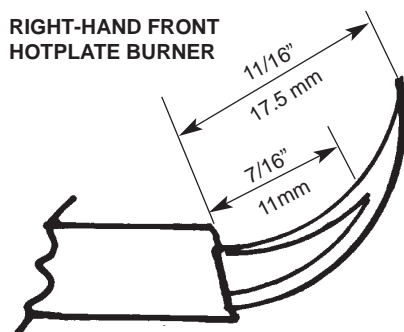

5. Installation introduction

⚠ CAUTION: This installation must conform with local codes or, in the absence of local codes to the national fuel gas code ANSI.Z223.1 and national electrical code ANSI/NFPA70 (in Canada CAN/CGA-B149) and only used in a well ventilated space, read the instructions before installing or using this appliance.

⚠ WARNING: This appliance shall be installed in accordance with the regulations in force and only used in a well ventilated space. Read the instructions before installing or using this appliance.

⚠ CAUTION: This unit is heavy, proper equipment and adequate manpower must be used in moving the range to avoid damage to the unit or the floor.

- Prior to installation, ensure that the local distribution conditions (nature of the gas and gas pressure) and the adjustment of the appliance are compatible.
- The adjustment conditions for this appliance are stated on the data plate.
- The data plate is situated in the centre vent slot near the base of the front plate.
- This appliance is not connected to a combustion products evacuation device. It shall be installed and connected in accordance with current installation regulations. Particular attention shall be given to the relevant requirements regarding ventilation.
- It should be in accordance also with any relevant requirements of the Gas Region and Local Authority.
- The appliance and its individual gas shut off valve must be disconnected from the gas supply piping system during any pressure testing of that system test pressure in excess of ½ psi (3.5 kPa).
- The appliance must be isolated from the gas supply piping system by closing its individual manual shut off valve during any pressure testing of the gas supply system at test pressures equal to or less than ½ psi (3.5 kPa).
- In your own interest, and that of safety to comply with the law, all gas appliances must be installed by a competent person. Failure to install appliances correctly could lead to prosecution.
- On completion, test the gas installation for tightness.
- On completion test the gas installation for soundness and purge. Leak testing of the appliance shall be conducted according to the manufacturers instructions.
- **NOTE:** Use soapy water solution on new gas connections to ensure there are no gas leaks.

⚠ WARNING: THIS APPLIANCE MUST BE EARTHED.

- The appliance is designed for the voltage stated on the data plate.
- The appliance is supplied with and installed adjacent to the left-hand side of R7/eR7 AGA cookers.
- Installation of the R7/eR7 Module must, therefore, be in conjunction with the build instructions of the 'parent' AGA.
- Reference must be made to the above Installation instructions for the 'parent' AGA especially regarding pre-site inspection, not only for both cookers but to consider any pipework that may pass at the rear of the Module. i.e. flue duct from a Fan Flue AGA.
- The appliance has been designed to accommodate pipework passing at the rear.
- **THE MAIN AGA COOKER IS DELIVERED EX-WORKS, FULLY ASSEMBLED.**
- **FINAL INSTALLATION IS UNDERTAKEN ON SITE, BY AN AUTHORISED AGA ENGINEER.**
- The AGA Module is supplied from the manufacturers in a fully assembled condition.
- It is the customers responsibility to contact a qualified electrical installer to make sure the electrical installation is adequate and in conformance with National Electrical Code ANSI/FPA 70- latest edition, and all local codes and ordinances.
- Take special care when cutting holes in walls or floor. Electrical wires may be behind the wall or floor covering and could cause an electrical shock if you touch them.
- Locate any electrical circuits that could be affected by the installation of this product and disconnect power circuit.
- Electrical grounding is required on this appliance.
- Do not have a fuse in the neutral or grounding circuit. A fuse in the neutral or grounding circuit could result in electrical shock.
- Do not use an extension lead with this appliance.
- Check with a qualified electrician if you are not sure the appliance is properly grounded .
- Failure to follow these instructions could result in death or serious injury.
- In the interest of safety, due consideration must be given to the protection of the electric cable to the module.

6. Location

Refer to **Fig. 3.1**

It is recommended that any soft material flooring is removed from where the Module will be installed.

Any adjacent walls that project above the height of the hob must be of heat resistant material.

The side wall above the hob shall be greater than 3" (76mm) from the cooker.

Surfaces over the top of the cooker must not be closer than 30" (762 mm) and must not exceed 13" (330mm) in depth.

The vent slots in the back of the top plate (or shroud) must not be obstructed.

If possible, any hot water pipes should be directed away from the cooker. In the event it is not possible the extension channel section at the rear of each side plate may be removed. If required to clear hot water or flue pipes with the following provisos:-

If hot water pipes pass at the rear, they should be lagged and a 1 15/16" (50 mm) air gap provided to the left-hand side of the cooker.

NOTE: It is advisable that the supply cable is routed away from any hot surfaces i.e. hot water/flue pipes.

In the interest of safety, due consideration must be given to the protection of the electric cable to the cooker.

If a supply cord is damaged it must be replaced by the manufacturer, its service agent or similarly qualified persons in order to avoid a hazard.

The appliance is designed for the voltage stated on the rating plate, which is situated in the centre vent slot near the base of the front plate.

Recommended, but not mandatory, to fit an individual Residual Current Device (RCD) for the cooker supply circuit to avoid nuisance tripping.

An electrical socket type 14-30R must be provided within 5 feet of the left-hand side of the range and accessible for disconnection.

DO NOT position socket above or behind the range.

An easily accessible manual shut off gas valve must be fitted before the metal flexi gas line supply to the range. **DO NOT** fit valve behind the range.

Any opening in the wall behind the appliance and in the floor under the appliance must be sealed.

A minimum clearance of 39 5/16" (1000 mm) must be available at the front of the cooker to enable it to be serviced.

⚠ DO NOT install the cooker behind a decorative door in order to avoid overheating.

7. Installation Sequence & Procedure

The cooker must be installed to local and national wiring regulations and carried out by a qualified engineer.

Having ensured all space requirements and regulations have been satisfied for the combined arrangement (AGA R7/eR7 & Module), the build and installation is to proceed as follows:-

It is essential that the base or hearth on which both cooker and module stands should be level and capable of supporting the total weight of both units.

- AGA eR7 = 816 lbs (370 kgs).
- AGA R7 = 978 lbs (444 kgs).
- Hotcupboard = 224 lbs (110 kgs).
- Module = 284 lbs (129 kgs).

1. Unpack and remove the Module from the pallet.
2. Check that the rear extension piece is secured to the left hand side panel.
3. Undo 2 screws from front location brackets and remove the bracket assembly. Now slide the Module off its plinth and set to one side **Fig. 7.1**.
4. The Module plinth can now be levelled and fitted up to the main appliance. Position the Module plinth alongside the AGA R7/eR7 leaving no gap between the two plinths. (See **Fig. 7.2**).
5. When fitting the Module against hotcupboard there should be a gap of $\frac{5}{8}$ " (16.5mm) which is achieved by using the spacers provided (See **Fig. 7.3**).
6. Check with a spirit level that the plinth is correct and using a straight edge check that both plinths are aligned along the front face (using either front or rear plinth adjustment screw to alter alignment, if necessary).
7. Also check height differential between the Module plinth and AGA R7/eR7 plinth is correct: $\frac{7}{16}$ " (11 mm). If necessary, use the adjusting studs in each corner to level the plinth. In extreme instances, shims may be used underneath the plinths (See **Fig. 7.2** or **Fig. 7.4**).
8. Attach Module plinth to the AGA R7/eR7 plinth using 2x M6 screws and washers provided (See **Fig. 7.5** or **Fig. 7.6**). Slide front jointing bracket into place over two adjacent magnets, locking the two appliances together.

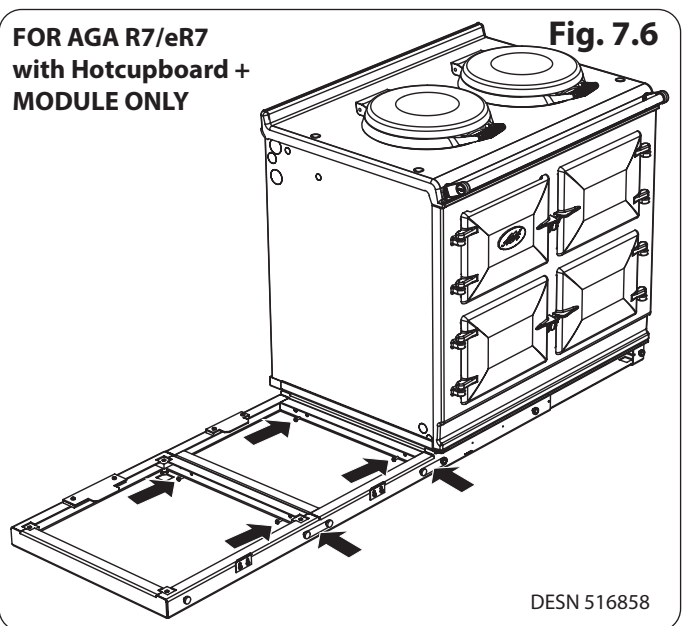
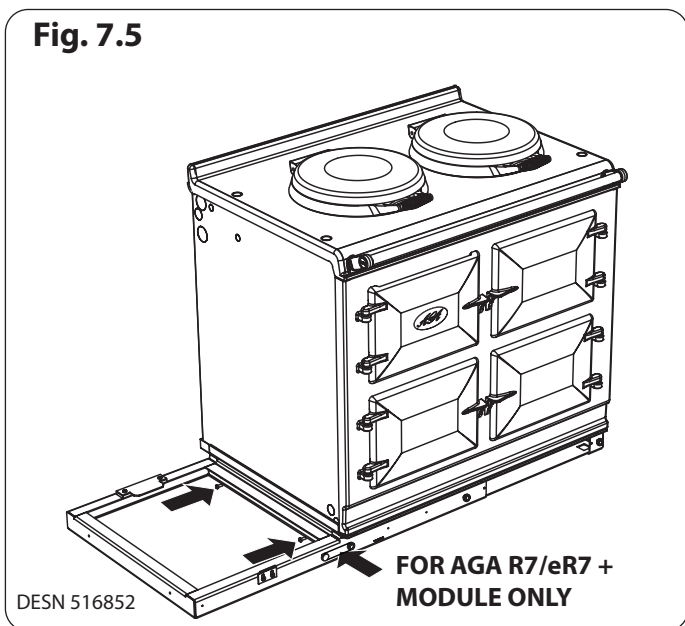
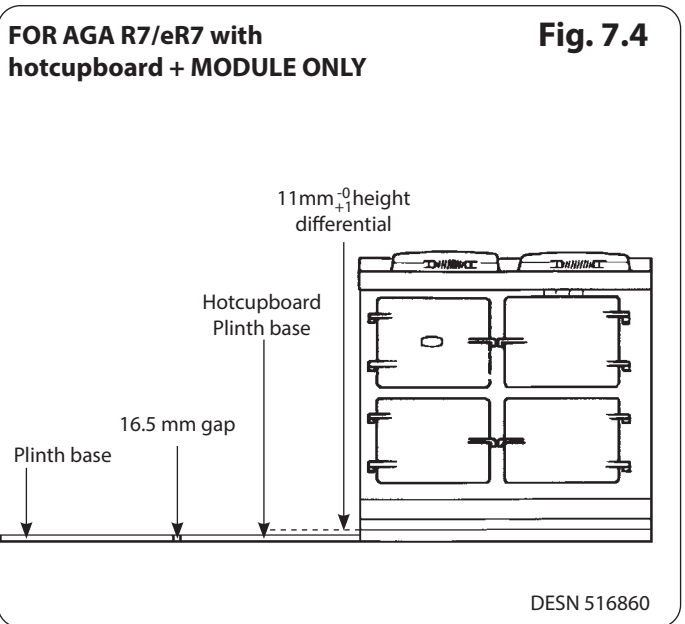
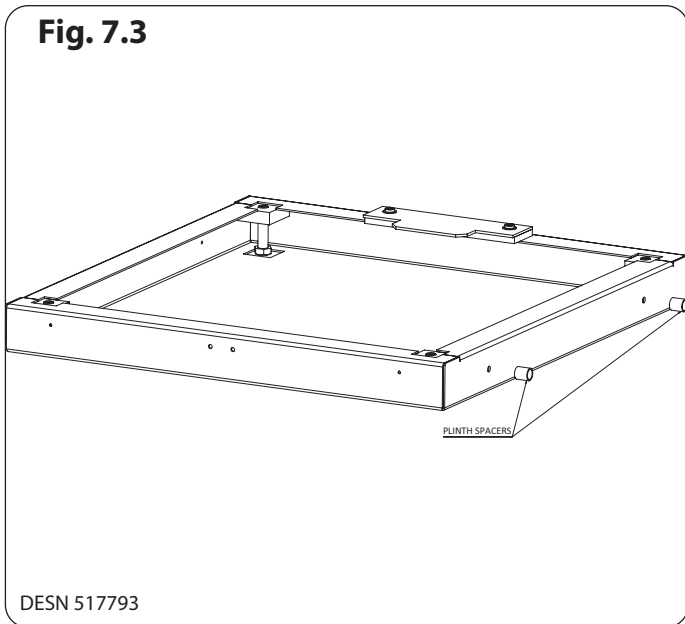
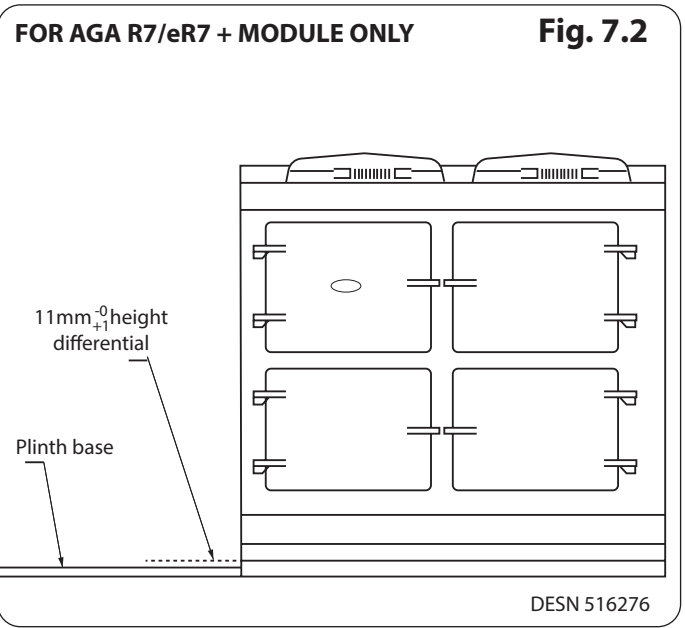
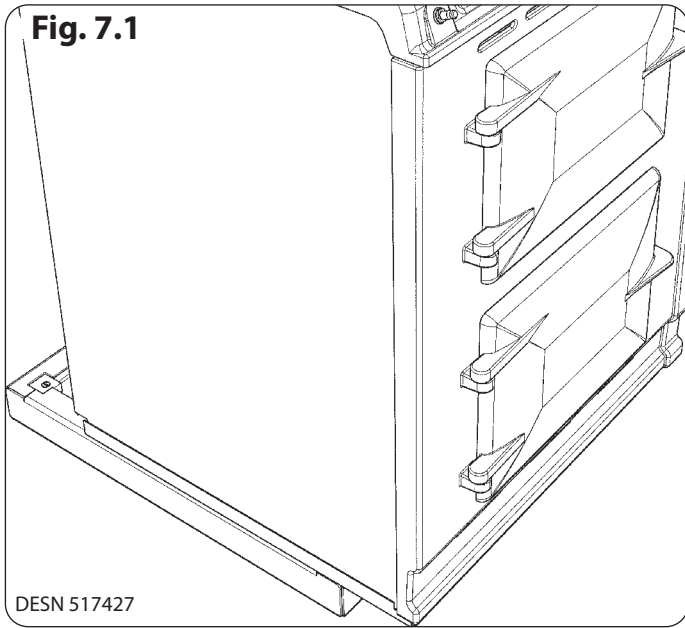

8. Chassis Installation

1. Prior to electrical connections, remove top plate assembly from Module as follows:-
2. Remove pan supports and all controls knobs.
3. Remove four chrome buttons and the four top plate retaining screws (2 each side).
4. Remove two screws from control panel (one from left hand hole and one from centre hole). (See **Fig. 8.1**).
5. Pull top plate forward slightly and lift up at front. Support top plate and disconnect wiring to the two neons. Remove top plate.
6. Lay the top plate on its top face, suitably protected.

Remove hotplate as follows:-

7. Remove burner heads and burner caps.
8. Remove all of the screws retaining hotplate burner trims (4 from Wok burner, 2 each from the other three burners). (See **Fig. 8.2**).
9. Carefully remove burner trims and gaskets, taking care not to damage gaskets or burner electrodes.
10. Disconnect earth wire from left hand control panel mounting bracket.
11. Remove hotplate casting.
12. Check power to the appliance is off and isolated.
13. Connect the mains wire to the terminal block at the rear of the cooker (See **Electrical Connections**).
14. Slide Module and plinth until rear tongue bracket engages fully into rear of base slot. (See **Fig. 8.3**). Ensure the appliance is aligned squarely with the plinth then proceed to engage the front tongue bracket into the slot on the underside of the base plate. Once satisfied that the front tongue bracket is engaged fully lock into place by tightening the two M6 screws fully.
15. Check to ensure that the Module front plate and AGA R7/eR7 front plate are the same height, and that the overlap strips correspond correctly. If not, adjustment should be made to the relevant appliance, at this stage.

Fig. 8.1

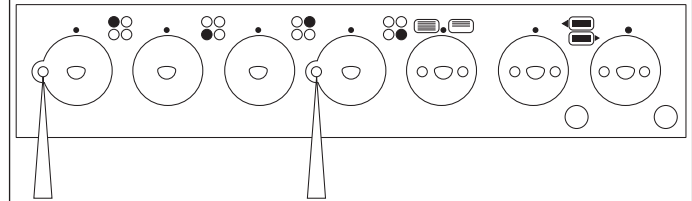

REMOVE 2 FIXING SCREWS

DESN 517426

Fig. 8.2

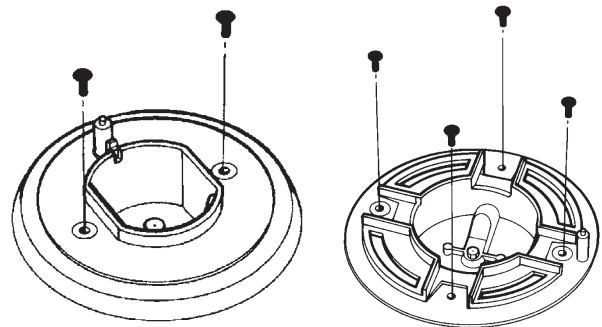

(WOK BURNER ONLY)

DESN 511646

Fig. 8.3

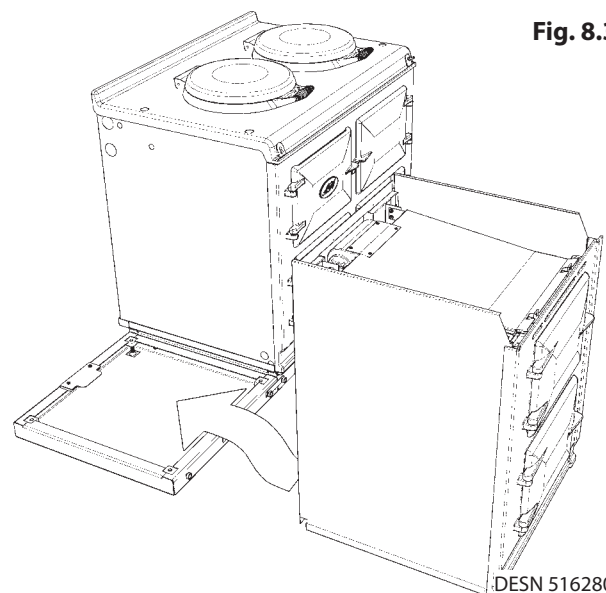

DESN 516280

Fig. 8.4

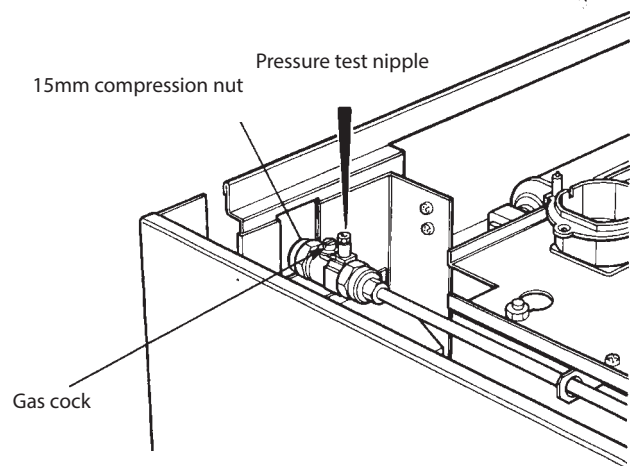

DESN 516858

Connecting To Gas

The cooker must be installed by connection to rigid pipework, which should not be less than 15 mm diameter. Connection is made to the 15 mm compression fitting located just below the hotplate level on the rear left hand side of the cooker.

1. Mark off approximate position on wall for gas supply to cooker (See Specification).
2. Isolate the gas supply and connect pipework as required up to the position marked.
3. Check for gas tightness after connecting the gas supply.
4. Make final gas connection to the cooker (15 mm compression) into the combined gas cock/pressure test fitting (See **Fig. 8.4**).
5. Check for gas tightness after connecting the gas supply.

Fig. 8.5

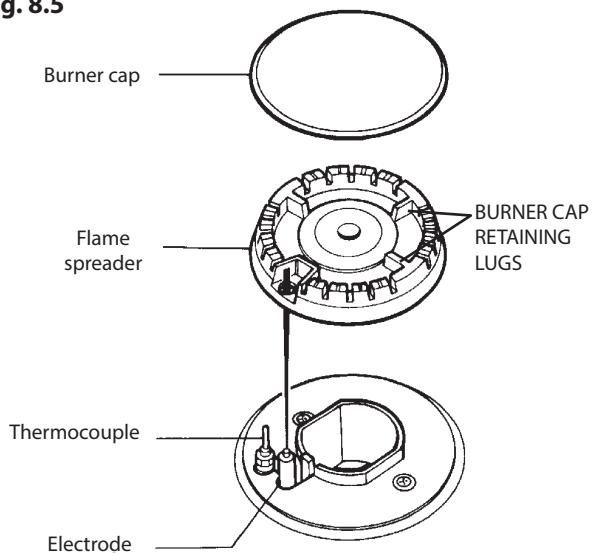

DESN 513513

Fig. 8.6

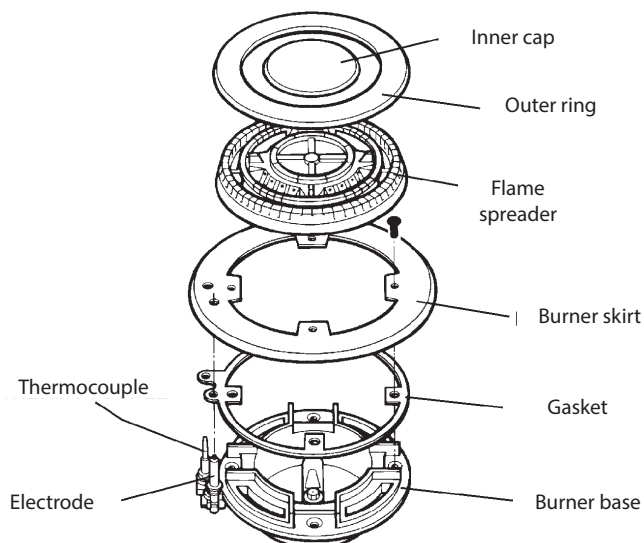

DESN 513898

9. Electrical Connections



Electric Shock Hazard

Electrical grounding is required on this range.

DO NOT connect to the electrical supply until the range is permanently grounded.

Disconnect the power to the junction box before making the electrical connection.

This range must be connected to a grounded, metallic, permanent supply or a grounding connector should be connected to the grounding terminal or wire lead on the range.

DO NOT ground to gas pipe. Failure to follow these instructions could result in death or serious injury.

A four-wire single phase 240-volt, 60-Hz, AC-only electrical supply is required on a separate, 30-amperes circuit, fused on both sides of the line.

A time-delay fuse or circuit breaker is recommended.

Local codes permit the use of a U.L.-listed, 250-volt, 30-amperes power cord (pigtail). This cord contains four No. 10 copper wires and matches a four-wire receptacle of type 14-30R **Fig. 9.1** Connectors on the appliance end must be provided at the point the power supply enters the appliance.

Wire sizes (**COPPER WIRE ONLY**) and connections must conform with the rating of range (30- amperes).

The wiring diagram is located on the back of the range.

1. Remove the terminal block cover screws located on the back of the range.
2. Make the four-wire connection following the “Power supply cord method”.
3. Assemble a U.L.-listed strain relief in the opening.
4. Insert the power supply cord through the strain relief, allowing enough slack to easily attach the wiring to the terminal block.
5. Use only ring-type terminals to connect the power supply. To secure the power supply cord use 6mm (¼”) brass terminal nuts attached to the inside of the terminal block cover. Be sure nuts are installed tight.
6. Complete electrical connection.
7. Apply tape (provided) to the rear of the lap strip on the Module front plate.
8. Slide Module onto plinth until rear tongue bracket engages fully into rear of base slot. (**Fig. 9.2**). Ensure the appliance is aligned squarely with the plinth. Check that the Module front plate and AGA 7 Series I front plate are the same height, and that the overlap strips correspond correctly. If not, adjustment should be made to the relevant appliance at this stage.

Then proceed to engage the front tongue bracket into the slot on the underside of the base plate, and lock into place by tightening the two M6 screws fully.

Fig. 9.1

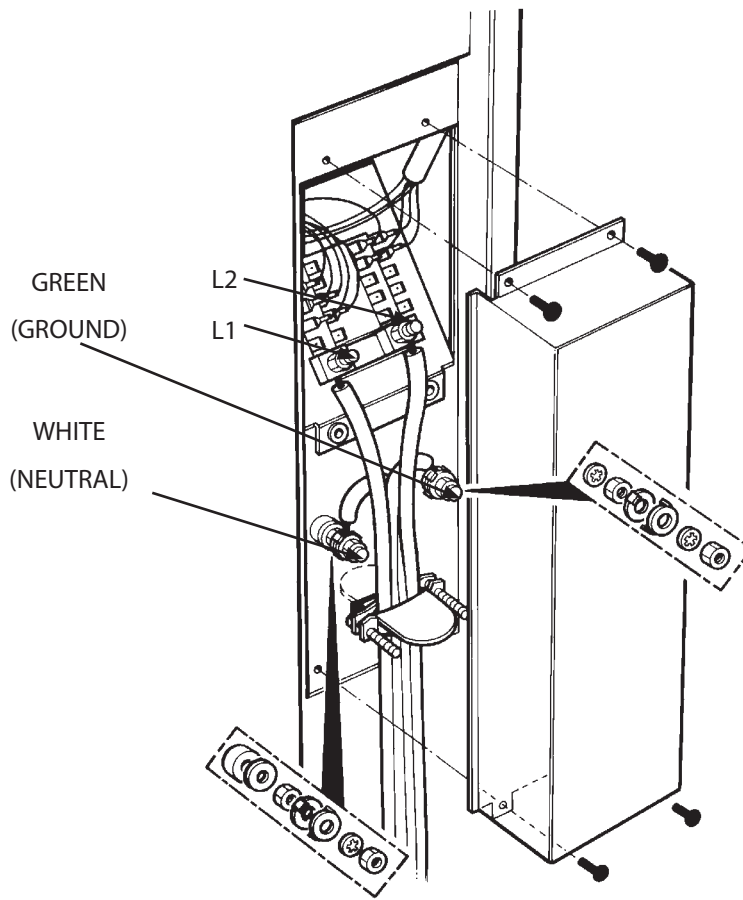

DESN 511752

Fig. 9.2

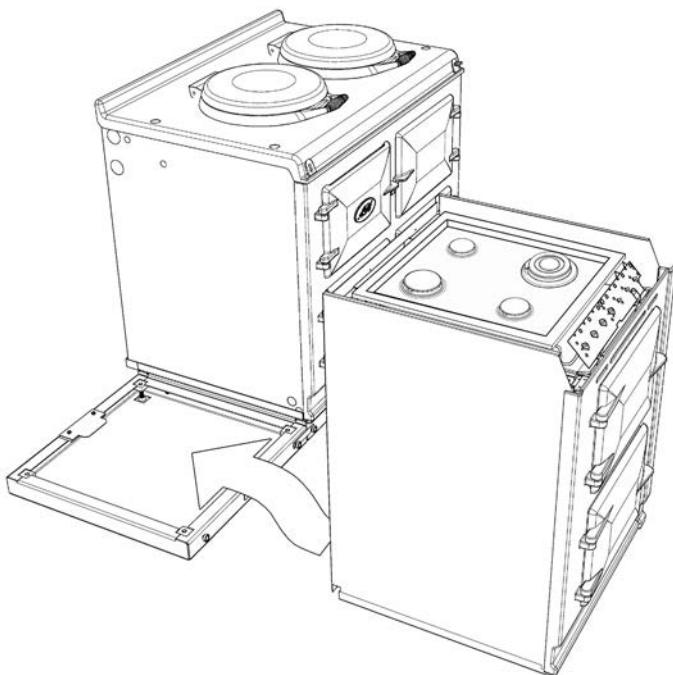

DESN 517044

10. Gas Connections

MODULE GAS SUPPLY CONNECTIONS

The cooker must be installed by connection to rigid pipework, which should not be less than $\frac{1}{2}$ " (15mm) diameter.

Connection is made to the $\frac{1}{2}$ " (15mm) compression fitting located just below the hotplate level on the rear left hand side of the cooker.

- a. Mark off appropriate position on wall for gas supply to cooker. **Fig. 3.1** or **Fig. 3.2** and **Fig. 10.1**.
- b. Isolate the gas supply and connect pipework as required up to the position marked.
- c. Check for gas tightness after connecting gas supply to the module.

Pressure Testing

The maximum gas inlet pressure to the appliance must not exceed 12" wg for N.G. and 14" for L.P. Gas. The minimum gas inlet pressure at the appliance must not be less than 5" w.g. Natural Gas and 11" wg L.P. Gas to enable the correct manifold pressure to be obtained (**Fig. 10.2**).

NOTE: The regulator is pre-set for either N.G. or L.P. Gas.

Use the small hotplate burner injector as the pressure test point.

Pressure Testing

The pressure test point is situated at the rear left hand side of the appliance just below hotplate level. (**Fig. 8.4**).

1. Remove screw from pressure test nipple. Fit the pressure gauge onto the pressure test nipple.
2. Turn the gas cock to the ON position.
3. Place one of the burner heads and burner cap into position on the burner body. Push in and turn the appropriate control knob anti-clockwise to full-on position, and light the burner with a match.
4. For Natural Gas appliance, the pressure should be nominal 20mbar (8 inches water gauge).
5. For LPG appliance (propane) the pressure should be nominal 37mbar (14.8 inches water gauge).
6. Turn off the tap, turn off gas cock, disconnect the pressure gauge and refit pressure test screw to pressure test nipple.
7. Turn the gas cock back to the ON position.
8. Check for gas tightness.

For Natural Gas manifold pressure is 4" w.g.

For L.P.G. (Propane Only) manifold pressure 10" w.g.

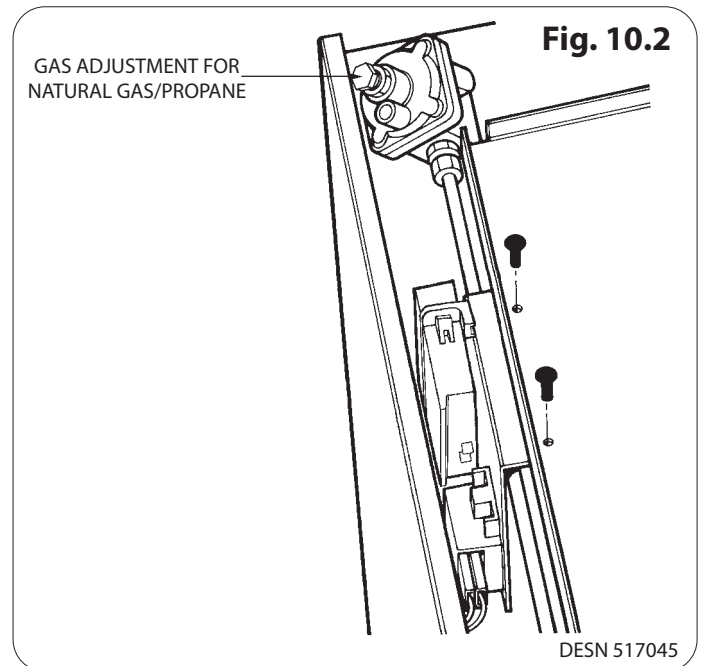
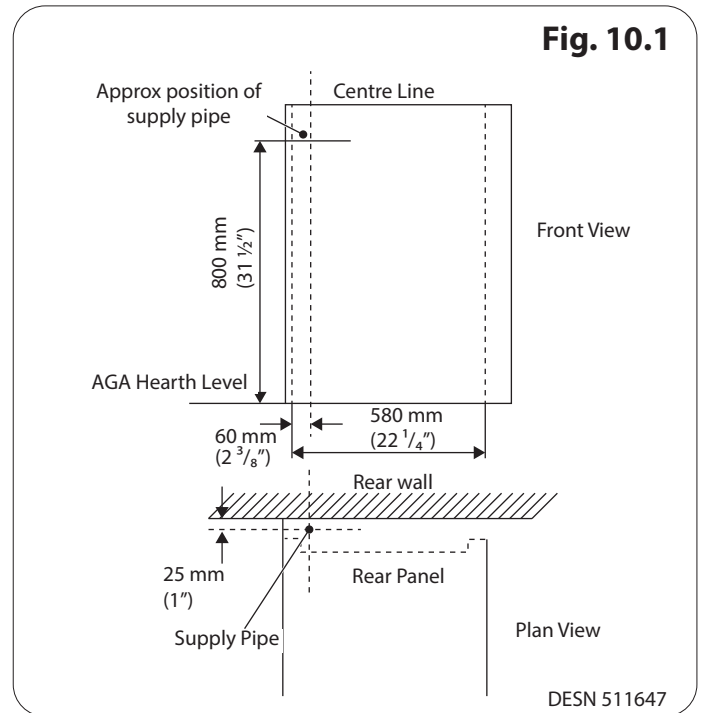

11. Final Fitting

Fig. 11.1

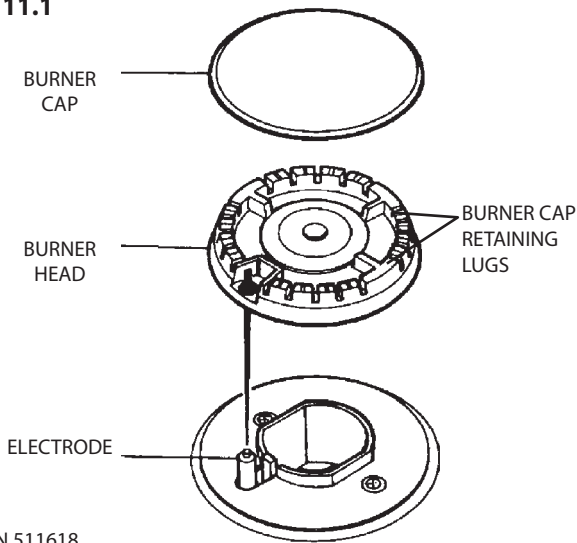

DESN 511618

Fig. 11.2

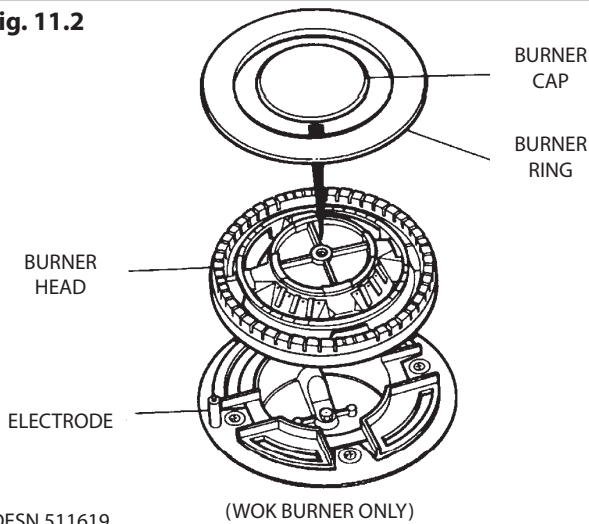

DESN 511619

Fig. 11.3

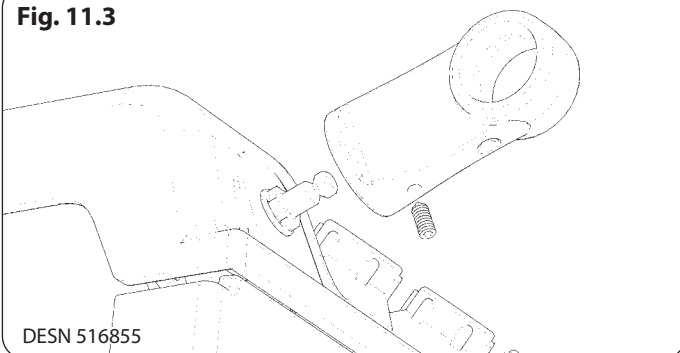

DESN 516855

Fig. 11.4

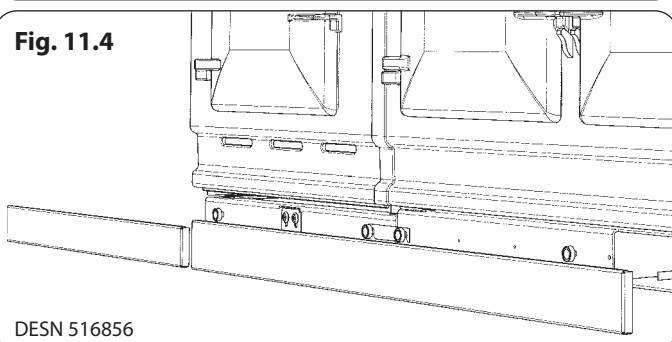

DESN 516856

1. Apply tape (provided) to the underside of the lap strip on the Module top plate.
2. Replace module hotplate. Reassemble in reverse order and reconnect the mains wire (See **Electrical Connections**). Ensure burner heads and burner caps are correctly located (See **Fig. 11.1** and **Fig. 11.2**), and electrodes are not damaged.

Replace Module top plate as follows:-

3. Support top plate at front and reconnect the Earth and wiring to the two neons.
4. Carefully lower the top plate into position taking care not to damage wiring or neons.
5. Ensure holes for control spindles are aligned correctly, and replace 2 screws into control panel.
6. Loosely screw the top plate down with 4 retaining screws.
7. Verify that the two top plates are level and proceed with tightening down.
8. Fit the Module handrail bracket over the fixing stud located on the top plate. Lock into position by tightening the grub screw nearest the appliance. (See **Fig. 11.3**).
9. Next, fit all thread stud into the insert located in the one end of the Module handrail, then feed the handrail through the bracket and screw the handrails together. (See **Fig. 11.4**).
10. Once the handrail assembly is located squarely, lock the handrail in position by winding in the grub screws on the underside of each handrail bracket.
11. Once the handrails are locked in position, fit the handrail endcaps. The endcaps should be carefully pushed into place until they sit flush with the outside face of each bracket (a light smear of lubricant such as, washing up liquid on the end cap 'O' rings may ease fitment).
12. Finally, fit the plinth fascia to the magnets on the front of the plinth, making sure that the right hand side of the Module plinth fascia sits against the left hand side of the R7 / eR7 plinth fascia leaving no gap between. Also, make sure that the plinth fascias are centrally located and do not overhang either appliance (See **Fig. 11.4**).
13. Commission the R7 / eR7, as stated in the relevant Installation Instructions and carry out functional test on each of the features of the Module.

12. Servicing Notes

DISCONNECT FROM ELECTRICITY SUPPLY BEFORE SERVICING.

WHEN RE-WIRING ANY ELECTRICAL COMPONENTS REFER TO CIRCUIT DIAGRAM AND ELECTRICAL SCHEMATIC DIAGRAM ATTACHED BEFORE ELECTRICAL RECONNECTION CHECK THAT THE APPLIANCE IS ELECTRICALLY SAFE.

NOTE: TURN OFF GAS SUPPLY TO RANGE BEFORE SERVICING ANY GAS CARRYING COMPONENTS. ALWAYS CHECK APPLIANCE FOR GAS SOUNDNESS AFTER COMPLETION.

NOTE: USE SOAPY WATER SOLUTION TO ENSURE THERE ARE NO GAS LEAKS.

A. REMOVAL OF TOP PLATE

1. Disconnect from electricity supply and remove pan supports and control knobs.
 - a. Remove the handrail from the module top plate.
 - b. Remove shroud (if fitted) from rear of top plate.
 - c. Remove four chrome buttons and the four top plate retaining screws (2 each side).
2. Remove left hand and centre grommets from the control panel to gain access to the fixing screws. Remove two screws from control panel (one from left hand hole and one from centre hole (**Fig. 8.1**)).
3. Carefully pull top plate forwards slightly and lift up at the front. Support top plate and disconnect the wiring to the neons. Remove top plate.
4. Lay the top plate on its top face, suitably protected.
5. Re-assemble in reverse order.

B. REMOVAL OF HOTPLATE

1. Repeat operations 1 to 5 of section 'A'.
2. Remove burner heads and burner caps.
3. Remove all of the screws retaining hotplate burner trims (4 from the Wok burner, 2 each from the other three burners).
4. Carefully remove burner trims and gaskets, taking care not to damage gaskets or burner electrodes.
5. Disconnect earth wire from left hand control panel mounting bracket.
6. Remove hotplate.
7. Re-assemble in reverse order, ensuring burner heads and burner caps are correctly located and electrodes are not damaged (**Fig. 12.1, Fig. 12.2, Fig. 12.3**)

C. TO CHANGE IGNITION GENERATOR

1. Turn off electricity supply.
2. Remove top plate and hotplate (See sections A and B).
3. Remove two screws retaining the generator fixing bracket to the burner mounting panel, and remove generator (**Fig. 12.4**).
4. Carefully remove all wiring from ignition generator (**Fig. 12.4**).
5. Re-assemble in reverse order and check operation of ignition to hotplate burners.

D. TO CHANGE IGNITION ELECTRODE

1. Turn off electricity supply.
2. Remove top plate and hotplate, (See sections A and B).
3. Disconnect the electrode cable from the ignition generator.
4. Remove spring clip retaining electrode to burner body (**Fig. 12.5**) and remove electrode and cable.
5. Replace with new electrode ensuring spring clip is correctly located into burner body.
6. Re-assemble in reverse order and check operation of ignition to hotplate burners.

E. TO CHANGE HOTPLATE GAS TAP

1. Turn off gas supply and electricity supply.
2. Remove top plate and hotplate (see sections A and B).
3. Remove controls mounting plate by removing the 6 screws (**Fig. 12.6**).
4. Disconnect supply pipes from rest of all 4 gas taps and pull wiring off tap switches.
5. Disconnect gas rail tube and remove 4 screws from gas rail support brackets (**Fig. 12.7**).
6. Remove gas rail/taps assembly and remove appropriate tap by removing 2 screws (**Fig. 12.8**).
7. Re-assemble in reverse order ensuring that the sealing ring is correctly located between the new tap and the gas rail. (Rewire as circuit diagram).
8. Check for gas soundness before fitting hotplate and top plate.
9. When re-assembled, check for correct operation of tap/tap ignition switches.

F. TO CHANGE OVEN THERMOSTAT/GRILL CONTROL

1. Turn off electricity supply.
2. Remove hotplate and top plate (see sections A and B).
3. Remove two screws retaining the thermostat/grill control to the controls panel.
4. Pull all of the wiring off the thermostat or grill control. The grill control can now be removed.
5. From inside the oven, unclip thermostat phial. (Top oven phial located at rear of oven; lower oven phial located at top right hand side).
6. Feed phial through hole in oven, then pull capillary up from side of range to remove thermostat.
7. Re-assemble in reverse order, ensuring thermostat phial and capillary are not damaged and phial is correctly located into retaining clips. (Rewire as circuit diagram).
8. Check operation of oven thermostat phial or grill control.

Access to the gas governor is as follows:-

- a. Remove pan supports and all control knobs.
- b. Remove four chrome buttons and the four plate retaining screws (2 each side).
- c. Remove left hand and centre grommets from the control panel to gain access to the fixing screws. Remove two screws from control panel (one from left hand hole and one from centre hole)(**Fig. 8.1**).
- d. Pull top plate forwards slightly and lift up at front. Support top plate and disconnect wiring to the two neons. Remove top plate.
- e. Lay the top plate on its top face, suitably protected.

NOTE (Fig. 12.9):

1. **IGNITION SWITCHES AND THERMOSTATS ARE SHOWN IN THE OFF POSITION WITH THE APPLIANCE COLD AND FAN OVEN DOOR IS CLOSED.**
2. **THE COOKER IS COLD (IE. CUT-IN & CUT-OUT NOT OPERATED)**

CAUTION: LABEL ALL WIRES PRIOR TO DISCONNECTION WHEN SERVICING CONTROLS WIRING ERRORS CAN CAUSE IMPROPER AND DANGEROUS OPERATION.

VERIFY PROPER OPERATION AFTER SERVICING

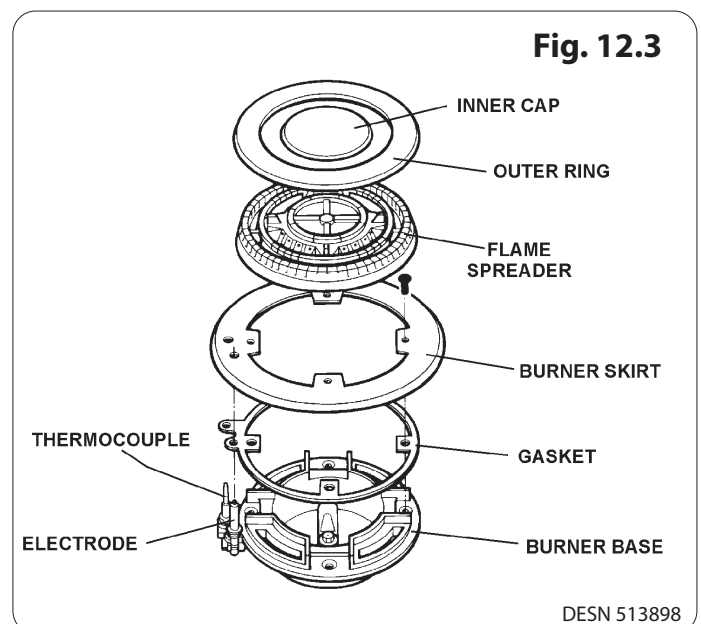
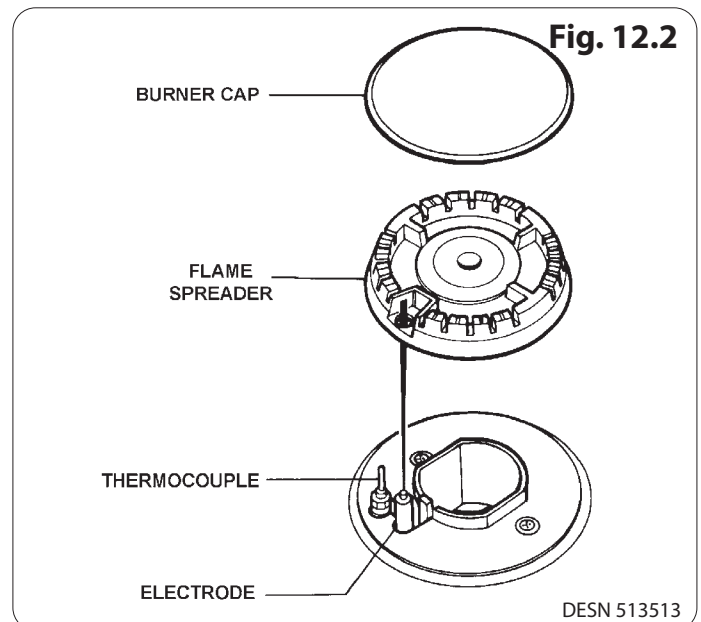
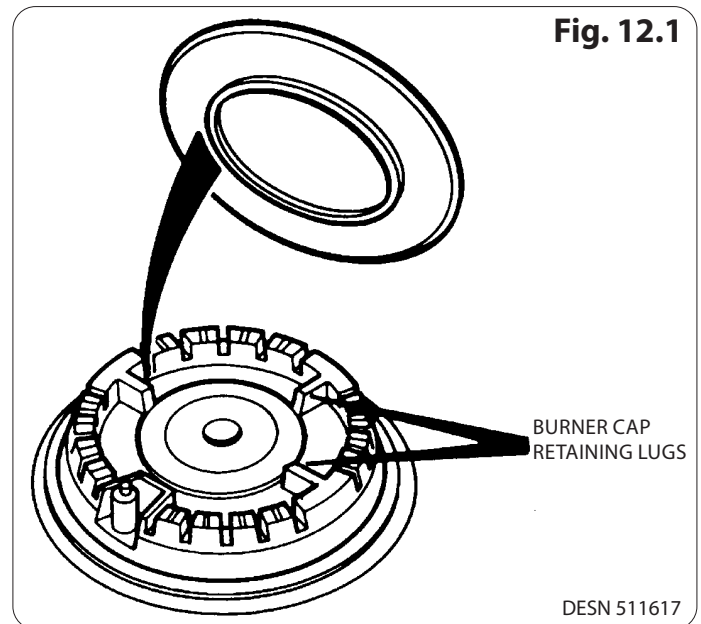
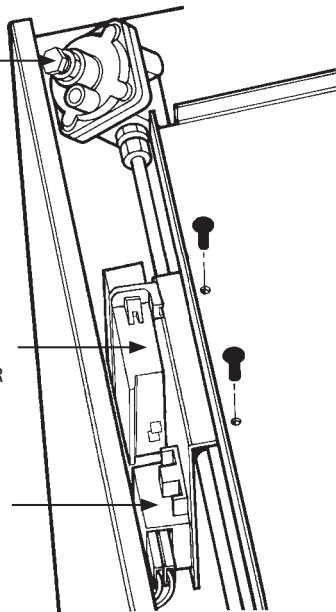

Fig. 12.4

GAS
ADJUSTMENT
FOR NATURAL
GAS/PROPANE

SPARK
GENERATOR

TERMINAL
BLOCK



DESN 517047

Fig. 12.5

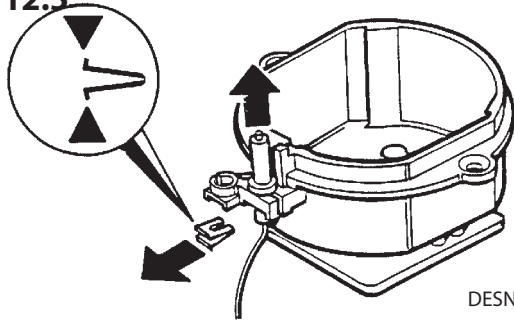

DESN 511649

Fig. 12.6

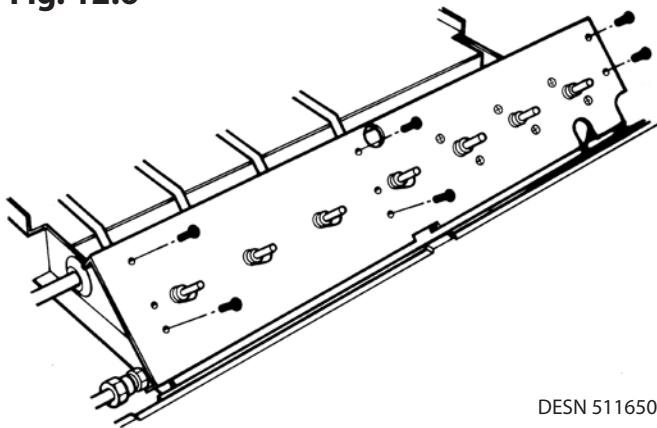

DESN 511650

Fig. 12.7

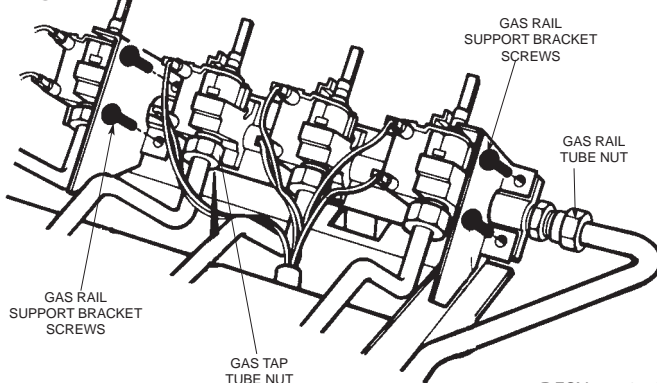

DESN 517976

Fig. 12.8

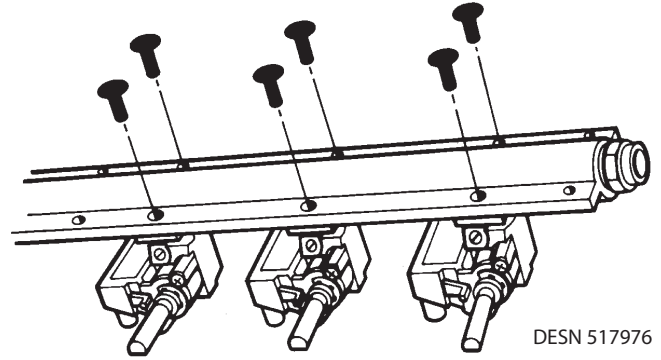

DESN 517976

Fig. 12.9

**AGA COMPANION/MODULE (WITH GAS HOB UNIT) - USA/CANADA
ELECTRICAL SCHEMATIC DIAGRAM
AGA COMPANION/MODULE (avec Unité plaque du cuisson)
SCHEMA DE CABLAGE ELECTRIQUE**

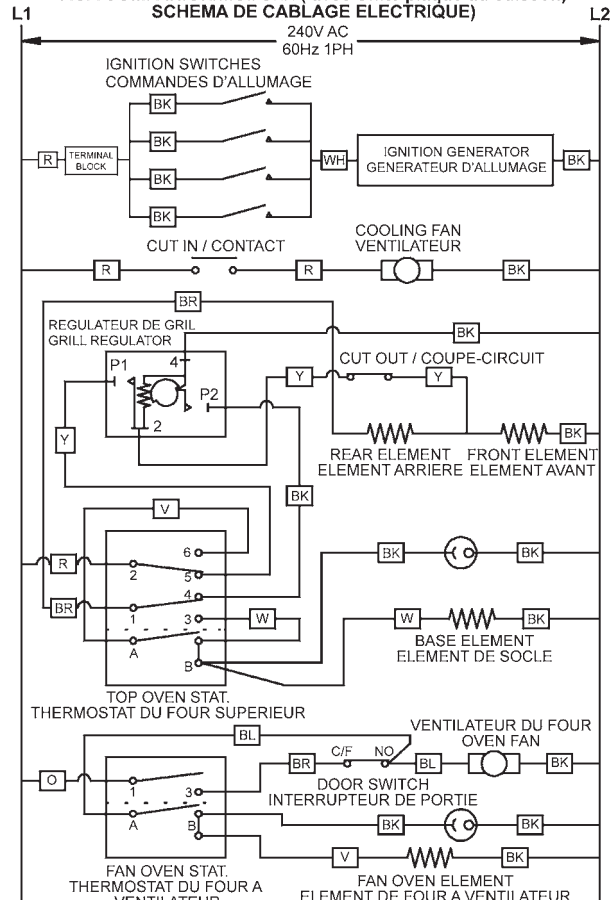

NOTE:

1. IGNITION SWITCHES AND THERMOSTATS ARE SHOWN IN THE OFF POSITION WITH THE APPLIANCE COLD AND FAN, OVEN DOOR IS CLOSED.
2. THE COOKER IS COLD (I.E. CUT-IN & CUT OUT NOT OPERATED).

1. LES COMMANDES D'ALLUMAGE ET LES THERMOSTATS SONT INDICUES DANS LA POSITION FERMEE AVEC L'APPAREIL FROID ET LA PORTE DU FOUR A VENTILATEUR FERMEE

2. LA CUISINIERE EST FROIDE (C'EST-A-DIRE QUE LE CONTACT ET LE COUPE-CIRCUIT NE SONT PAS ACTIONNES)

CAUTION: LABEL ALL WIRES PRIOR TO DISCONNECTION, WHEN SERVICING CONTROLS WIRING ERRORS CAN CAUSE IMPROPER AND DANGEROUS OPERATION. VERIFY PROPER OPERATION AFTER SERVICING.

ATTENTION: ÉTIQUETEZ TOUS LES CABLES AVANT DE LES DEBRANCHER LORS DE LES BRANCHER LORS DE L'ENTRETIEN DES COMMANDES. DES ERREURS DE CABLAGE PEUVENT ENTRAINER UN FONCTIONNEMENT INCORRECT ET DANGEREUX.

VERIFIEZ QUE L'APPAREIL FONCTIONNE CORRECTEMENT APRES L'ENTRETIEN. ALL WIRES WILL BE EITHER RED OR BLACK. THE WIRER HAS BEEN COLOUR CODED AT EACH END.

TOUS LES FILS SERONT ROUGES OU NOIRS - POUR FACILITER L'ASSEMBLAGE, LES FILS ONT ÉTÉ CODIFIÉS PAR COULEUR À CHAQUE EXTREMITÉ.

USE COPPER CONDUCTORS ONLY
UTILISER UNIQUEMENT DES CONDUCTEURS EN CUIVRE.

COLOUR KEY / COULEURS
BR - BROWN / MARRON
BK - BLACK / NOIR
BL - BLUE / BLEU
Y - YELLOW / JAUNE
O - ORANGE
R - RED / ROUGE
V - VIOLET
W - WHITE / BLANC
G - GREEN / VERT

EGLL 511781 D

13. Circuit Diagram

Fig. 13.1

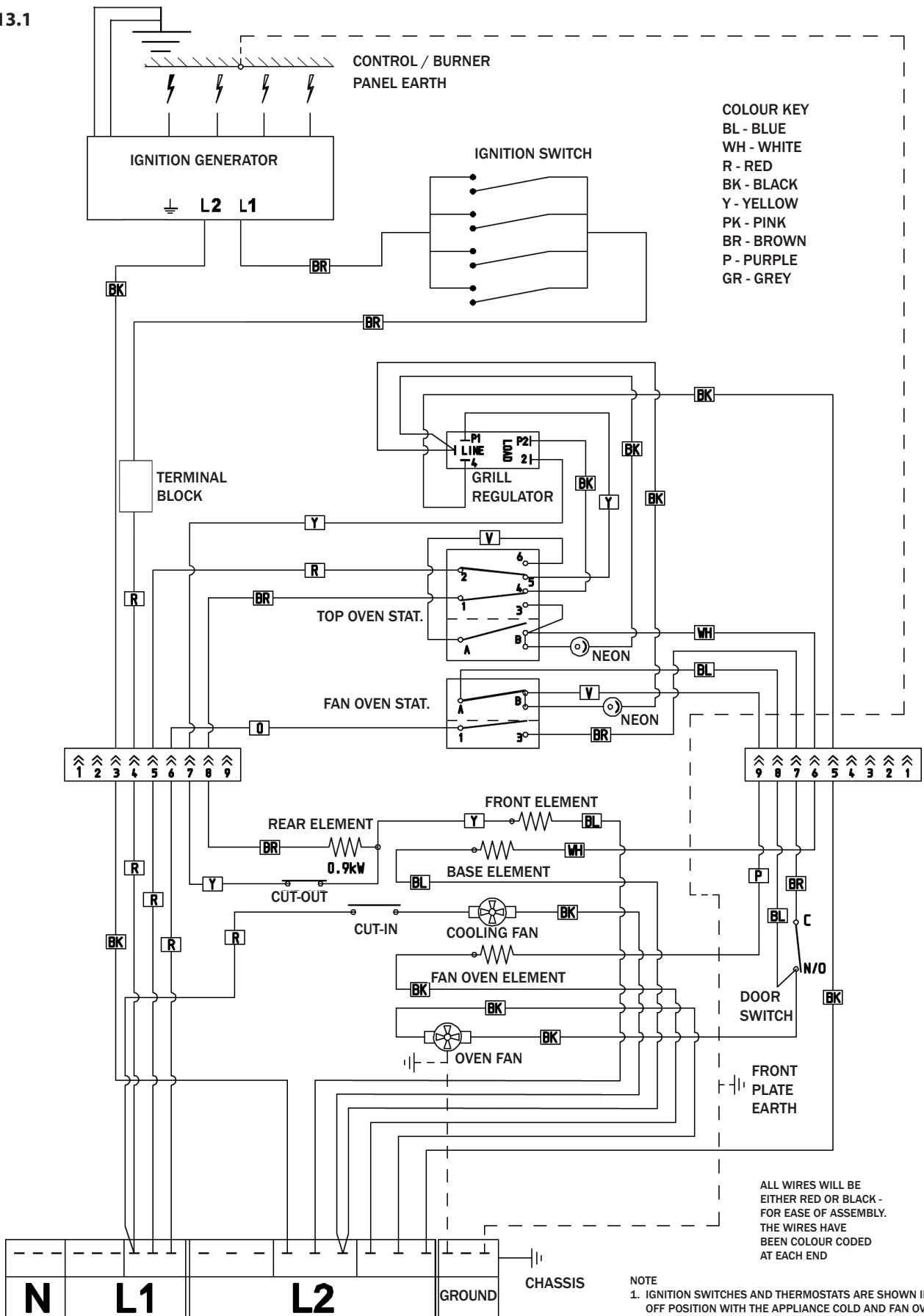

EGLL 515296

14. Servicing and warranty

- Your AGA does not need to be regularly serviced.
- Fans may need periodic replacement.
- In the event of requiring maintenance, please call AGA Service or your authorised distributor.
- Your appliance **MUST** only be maintained and installed by a qualified engineer, AGA engineer or an authorised distributor.
- **DO NOT** alter or modify the appliance.

The appliance warranty does not cover Commercial use (see separate Warranty book provided for further details).

**For further advice or information contact
your local AGA Specialist**

With Middleby Residential policy of continuous product improvement, the Company reserves the right to change specifications and make modifications to the appliance described and illustrated at any time.



Middleby Residential

4960 Golden Pkwy

BLDG 3

Buford, GA 30518

Business 770.932.7282

Fax 770.932.7292

Toll Free Telephone 800.241.9152